

KATALOG • CATALOGUE
CATALOGO • CATALOGUE

SWISS GAS FLUE SYSTEMS 

hearth 



DE - FR - IT - EN

ALMEVA AG









Merkmale • Caractéristiques Caratteristiche • Features

Technologie / Technologie / Tecnologia / Technology

Neue Technologien / Nuove tecnologie Nouvelles technologies / New technologies

	Go Fast - schnellere Zündung Go Fast - allumage plus rapide Go Fast - accensione rapida Go Fast - faster pellet ignition		Anschluss an das Heizungssystem Raccordement au système de chauffage Collegamento al sistema di riscaldamento Connection to the heating system		Idrotech - Brennschale selbstreinigend Idrotech - brasier autonettoyant Idrotech - braciare autopulente Idrotech - automatic brazier cleaning
	Integrierter konzentrischer Auslass Sortie concentrique intégrée Uscita concentrica integrata Integrated concentric outlet (80 - 130 mm)		5 Sterne Clean AirTM 5 étoiles Clean AirTM 5 stelle AriaPulitaTM 5 stars Clean AirTM		4-star Clean AirTM mit 5-Sterne-Staubemissionen avec des émissions de poussières 5 étoiles con emissioni polveri da 5 stellebut with 5-star dust emissions PP <=15 (mg/Nm³)
	Feuerschale aus Gusseisen Brasero en fonte Braciare in ghisa Cast iron brazier		Bausatz für konzentrischen Rauchabzug (optional) Kit conduit fumée concentrique (optionnel) Kit fumi concentrico (opzionale) Concentric flue kit (optional)		Abgedichteter Verbrennungsraum Chambre de combustion étanche Camera di combustione stagna Sealed combustion chamber
	Innenraum aus Gusseisen mit Sekundärluftverbrennung Intérieur en fonte à combustion d'air secondaire Interno in ghisa con combustione d'aria secondaria Cast iron inner with secondary air combustion		Gusseisentür Porte en fonte Porta in ghisa Cast iron door		Innenraum aus Schamotte mit Sekundärluftverbrennung Intérieur réfractaire à combustion d'air secondaire Interno in refrattario con combustione d'aria secondaria Refractory stone inner with secondary air combustion
	Innenraum aus Gusseisen mit Sekundärluftverbrennung Intérieur en fonte à combustion d'air secondaire Interno in ghisa con combustione d'aria secondaria Cast iron inner with secondary air combustion		Magic Glass		Shield
	Sicht des Backofens Vue sur le four Vista sul forno View on the oven		Kochen Cuisiner Cucinare Cooking		Fernbedienung (optional) Télécommande (optionnel) Telecomando (opzionale) Remote Control (optional)
	Integriertes WiFi Wi-Fi intégré Wi-Fi integrato Integrated Wi-Fi		Integriertes Bluetooth Bluetooth intégré Bluetooth integrato Integrated Bluetooth		Comfort mode
	Lüftungs- und Beleuchtungs-Kit (optional) Kit de ventilation et éclairage (optionnel) Kit ventilazione e illuminazione (opzionale) Ventilation and lighting kit (optional)		Komplett-Set Hydro Heizung + Brauchwasser Kit complet Idro chauffage + eau sanitaire Kit completo Idro riscaldamento + acqua sanitaria Complete kit heating + domestic water		Tägliche/Wöchentliche Programmierung Programmation quotidienne/hebdomadaire Programmazione giornaliera/settimanale Daily/Weekly Programming
	Lufttemperatursensor AIR		Wassertemperatursensor H ₂ O		Externer Thermostatanschluss Connexion du thermostat externe Collegamento termostato esterno External thermostat connection
	Kit für Kanalisierung (optional) Kit canalisation (optionnel) Kit canalizzazione (opzionale) Ducting kit (optional)		Kanalisierung mit 1 unabhängigen Luftgebläse Conduits d'aération avec 1 moteur indépendant Canalizzazione 1 motore indipendente Duction with 1 independent motor		Kanalisierung mit 2 unabhängigen Luftgebläsen Conduits d'aération avec 2 moteurs indépendants Canalizzazione 2 motori indipendenti Duction with 2 independent motors
	Anschluss an das Heizungssystem Raccordement au système de chauffage Collegamento al sistema di riscaldamento Connection to the heating system		Inklusive Hydraulikset Kit hydraulique inclus Kit idraulico incluso Hydraulic kit included		

Installationsweise / Mode d'installation / Modalità d'installazione / Installation mode

	Rauchauslass oben, hinten und seitlich Sortie de fumée en haut, à l'arrière et latéral Scarico fumi superiore, posteriore e laterale Smoke exhaust top, rear and lateral		Rauchauslass oben und hinten Sortie de fumée en haut et à l'arrière Scarico fumi superiore e posteriore Smoke exhaust top and rear		Rauchauslass oben Sortie de fumée en haut Scarico fumi superiore Smoke exhaust top
	Rauchauslass hinten Sortie de fumée à l'arrière Scarico fumi posteriore Smoke exhaust rear		Rauchauslass seitlich Sortie de fumée latéral Scarico fumi laterale Smoke exhaust lateral		Obere und hintere Kanalisierung Canalisation supérieure et arrière Canalizzazione superiore e posteriore Top and rear ducting
	Eingebaut Encastrable Da Incasso Built-in		Freistehend Libre installation Libera installazione Freestanding		

Merkmale • Caractéristiques Caratteristiche • Features



Nennleistung
Puissance nominale
Potenza nominale
Nominal power



Gesamtwärmeleistung
Puissance thermique globale
Potenza al focolare
Heating input



Verminderte Leistung
Puissance reduite
Potenza ridotta
Reduced power



Raumheizvermögen min/max
Volume à chauffer min/max
Volume riscaldabile min/max
Heatable volume min/max



Fassungsvermögen Pelletbehälter
Capacité du réservoir à pellets
Capacità del serbatoio pellet
Pellet hopper capacity



Nutzleistung zu Nennwasser
Puissance utile à eau nominale
Potenza utile all'acqua nominale
Useful power to nominal water



Nutzleistung in geregeletem Wasser
Puissance utile à l'eau reduite
Potenza utile all'acqua ridotta
Useful power in reduced water



Wirkungsgrad bei Nennleistung
Rendement nominal
Rendimento nominale
Nominal performance



Wirkungsgrad bei verminderter Leistung
Rendement réduit
Rendimento ridotto
Reduced performance



Stundenverbrauch min/max
Consommation horaire min/max
Consumo orario min/max
Hourly consumption min/max



Autonomie min/max
Autonomie min/max
Autonomia min/max
Range min/max



Brennstoff Pellet
Combustible pellet
Combustibile a pellet
Pellet fuel



Brennstoff Holz
Combustible bois
Combustibile legna
Wood fuel



Rauchabzug
Évacuation des fumées
Scarico fumi
Smoke exhaust



Verbrennungslufteinlass
Entrée d'air de combustion
Preso aria combustione
Combustion air inlet



Kanalauslass
Sortie canalisation
Uscita canalizzazione
Ducting outlet



Abmessungen Verpackung
Dimensions d'emballage
Misure imballo
Packing dimensions



Verpackungsvolumen
Volume d'emballage
Volume imballo
Packing volume



Nettogewicht
Poids net
Peso netto
Net weight



Abmessungen Backofen
Dimensions du four
Misure forno
Oven dimensions



Abmessungen Brennkammer
Mesures entree foyer
Misure bocca fuoco
Fire box dimensions



Kochfeldhöhe
Hauteur table de cuisson
Altezza piano cottura
Cooktop height

Pellet Air

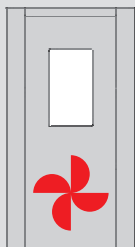

Almeva bietet ein komplettes Sortiment an Pelletöfen mit Umluft an, die mit einer versiegelten Kammer für höhere Effizienz und geringeren Verbrauch ausgestattet sind. Alle Modelle der Pellet Air Öfen sind Energieklasse A+ zertifiziert, 4x Sterne Air Clean, 7x Sterne Flamme Verte und entsprechen den EcoDesign 2022-Richtlinien.

Pellet Air Plus

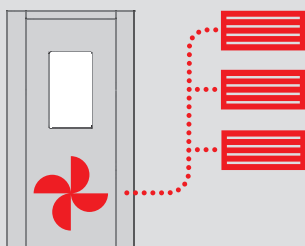

Der kanalisierbare Pellet Air Plus Ofen ist das ideale Gerät, um mehrere Räume im Haus auf wirtschaftliche und praktische Weise zu heizen. Dank des Kanalsystems kann die Wärme schnell und gleichmässig auf verschiedene Räume verteilt werden. Alle Modelle der Pellet Air Plus Öfen sind Energieklasse A+ zertifiziert, 4x Sterne Air Clean, 7x Sterne Flamme Verte und entsprechen den EcoDesign 2022-Richtlinien.

Pellet Hydro

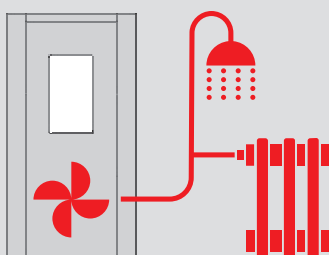

Die Thermoöfen sind eine optimale Lösung für das Heizsystem im Haus, da sie auch das Wasser in den Heizkörpern schnell erhitzen. Sie sind praktisch, wirtschaftlich und verbinden Funktionalität mit attraktiver Ästhetik. Einige Modelle sind in der H2O-Version erhältlich: Mit einem speziellen Bausatz ausgestattet, können diese Pelletöfen auch Haushaltswarmwasser erzeugen. Alle Modelle der Pellet-Hydro-Öfen sind Energieklasse A+ zertifiziert, 4x Sterne Air Clean, 7x Sterne Flamme Verte und entsprechen den EcoDesign 2022-Richtlinien.

Almeva propose une gamme complète de poêles à pellets à air ventilé équipés d'une chambre étanche pour un meilleur rendement et une consommation réduite. Tous les modèles de poêles Pellet Air sont certifiés classe énergétique A+, 4x étoiles Air Clean, 7x étoiles Flamme Verte et répondent aux directives EcoDesign 2022.

Almeva offre una gamma completa di stufe a pellet ad aria ventilata dotate di camera stagna per una maggiore efficienza e un minor consumo. Tutti i modelli di stufe Pellet Air sono certificati in classe energetica A+, 4x stelle Air Clean, 7x stelle Flamme Verte e rispettano le linee guida EcoDesign 2022.

Almeva offers a complete range of ventilated air pellet stoves with a sealed chamber for greater efficiency and reduced consumption. All Pellet Air stove models are energy class A+ certified, 4x stars Air Clean, 7x stars Flame Verte and comply with the EcoDesign 2022 guidelines.

Le poêle canalisable Pellet Air Plus est l'appareil idéal pour chauffer plusieurs pièces de la maison de manière économique et pratique. Grâce au système de conduits, la chaleur peut être distribuée rapidement et uniformément dans les différentes pièces. Tous les modèles de poêles Pellet Air Plus sont certifiés classe énergétique A+, 4x étoiles Air Clean, 7x étoiles Flamme Verte et répondent aux directives EcoDesign 2022.

La stufa canalizzabile Pellet Air Plus è l'apparecchio ideale per riscaldare diverse stanze della casa in modo economico e pratico. Grazie al sistema di canalizzazione, il calore può essere distribuito rapidamente e uniformemente nelle diverse stanze. Tutti i modelli di stufe Pellet Air Plus sono certificati in classe energetica A+, 4x stelle Air Clean, 7x stelle Flamme Verte e rispettano le linee guida EcoDesign 2022.

The Pellet Air Plus ductable stove is the ideal device to heat several rooms in the house in an economical and practical way. Thanks to the duct system, the heat can be distributed quickly and evenly to different rooms. All Pellet Air Plus stove models are energy class A+ certified, 4x stars Air Clean, 7x stars Flame Verte and comply with the EcoDesign 2022 guidelines.

Les thermo-poêles sont une solution optimale pour le chauffage domestique, car ils chauffent rapidement l'eau des radiateurs. Ils sont pratiques, économiques et allient fonctionnalité et esthétique attrayante. Certains modèles sont disponibles dans la version H2O: équipés d'un kit spécial, ces thermo-poêles à pellets peuvent produire de l'eau chaude sanitaire. Tous les modèles de poêles Pellet Hydro sont certifiés classe énergétique A+, 4x étoiles Air Clean, 7x étoiles Flamme Verte et répondent aux directives EcoDesign 2022.

Le termostufe sono una soluzione ottimale per l'impianto di riscaldamento domestico, poiché riscaldano anche l'acqua nei radiatori rapidamente. Sono pratici, economici e combinano la funzionalità con un'estetica piacevole. Alcuni modelli sono disponibili nella versione H2O: dotate di un kit speciale, queste stufe a pellet possono anche produrre acqua calda sanitaria. Tutti i modelli di stufe Pellet Hydro sono certificati in classe energetica A+, 4x stelle Air Clean, 7x stelle Flamme Verte e rispettano le linee guida EcoDesign 2022.

Thermostoves are an excellent solution for domestic heating systems, as they also heat the water in the radiators quickly. They are practical, economical and combine functionality with attractive design. Some models are available in the H2O version: equipped with a special kit, these pellet thermostoves can also produce domestic hot water. All Pellet Hydro stove models are energy class A+ certified, 4x stars Air Clean, 7x stars Flame Verte and comply with the EcoDesign 2022 guidelines.

Neue Technologien • Nouvelles technologies Nuove tecnologie • New technologies

Flexit

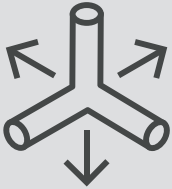

Die Flexit-Technologie bietet eine hervorragende **Flexibilität bei der Installation**, sowohl hinsichtlich des Rauchgasabzugs (hinten, oben, oben-konzentrisch) als auch beim kanalisierbaren Warmluftabzug (hinten oder oben).

La tecnologia Flexit garantisce un'eccellente **flexibilità in termini di installazione**, tant en ce qui concerne la sortie des fumées (qui peut être arrière, supérieure-concentrique) que celles de l'air chaud canalisable (arrière ou supérieure).

La tecnologia Flexit garantisce un'ottima **flessibilità in termini di installazione**, sia per quanto concerne l'uscita dei fumi (possono essere posteriori, superiori, superiori-concentriche) che quelle d'aria calda canalizzabile (posteriori o superiori).

Flexit technology guarantees excellent **flexibility in terms of installation**, both in terms of smoke outlet (can be rear, top, top-concentric) and ductable hot air outlet (rear or top).

Seitliche Belüftung ist bei den Plus-Modellen Standard
La ventilation latérale est standard sur les modèles Plus
La ventilazione laterale è standard sui modelli Plus
Side ventilation is standard on Plus models

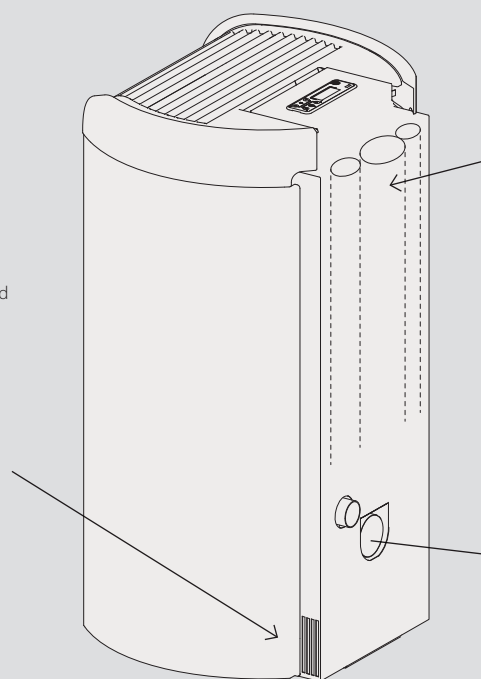

Oberer Rauchauslass wahlweise mit Bausatz Ø 80 oder Bausatz Ø 130 koaxial

Option de sortie de fumée supérieure avec kit Ø 80 ou kit Ø 130 coaxial

Opzione uscita fumi superiore con kit Ø 80 o con kit Ø 130 coassiale

Upper smoke outlet option with kit Ø 80 or with kit Ø 130 coaxial

Luft-Kanalisierung wahlweise hinten oder oben
Possibilité canalisation d'air arrière ou supérieure

Possibilità di canalizzazione aria posteriore o superiore
Possibility of rear or top air ducting

Rauchauslass
Sortie de fumée
Uscita fumi
Smoke outlet

5 Sterne / 5 étoiles 5 stelle / 5 stars



Die Pellet-Öfen erfüllen das **AriaPulita™-Zertifizierungssystem**, welches Öfen auf der Grundlage ihrer Energieeffizienz und ihrer Emissionen bewertet. Mit 5 AriaPulita™-Sterne werden Pellet-Öfen und Pellet-Einsätze ausgezeichnet, die im Vergleich zu 1-Sterne-Geräten 80% weniger Partikelemissionen garantieren.

Les poêles à pellets répondent au système de **certification AriaPulita™**, qui évalue les poêles sur la base de leur efficacité énergétique et de leurs émissions. 5 étoiles AriaPulita™ sont attribuées aux poêles et aux inserts à pellets qui garantissent 80% d'émissions de particules en moins par rapport aux appareils à 1 étoile.

Le stufe a pellet sono conformi al sistema di **certificazione AriaPulita™**, che valuta le stufe in base alla loro efficienza energetica e alle emissioni. 5 stelle AriaPulita™ sono assegnate alle stufe e inserti a pellet che garantiscono l'80% in meno di emissioni di particelle rispetto agli apparecchi a 1 stella.

The pellet stoves comply with the **AriaPulita™ certification system**, which evaluates stoves based on their energy efficiency and emissions. The 5 AriaPulita™ stars are awarded to pellet stoves and inserts that guarantee 80% fewer particle emissions compared to 1-star devices.

Idrotech



Idrotech ist das innovative **automatische Reinigungssystem** des Feuerraumes, das die Ascheablagerungen im Feuerraum automatisch entfernt und somit die tägliche Reinigung des Feuerraums vermeidet. Der Brenner wird in regelmäßigen Abständen und bei Feststellung von Ascheverstopfung mechanisch ausgekratzt. Dadurch wird sichergestellt, dass die Verbrennung immer perfekt und effizient ist.

Idrotech est le système innovant de qui élimine automatiquement les dépôts de cendres dans le brasier et évite ainsi le nettoyage quotidien du foyer. Le brûleur est racle mécaniquement à intervalles réguliers et dès qu'un encrassement des cendres est constaté. Cela permet de garantir une combustion toujours parfaite et efficace.

Idrotech è l'innovativo sistema di **pulizia automatica del braciere** che asporta automaticamente i depositi di cenere nel braciere ed evita pertanto la pulizia giornaliera del focolare. È previsto un raschiamento meccanico del braciere ad intervalli regolari e al rilevamento di un intasamento di cenere. In questo modo la combustione è sempre perfetta ed efficiente.

Idrotech is the innovative **automatic brazier cleaning** system that automatically removes ash deposits in the brazier, thus avoiding daily cleaning of the firebox. The burner is mechanically scraped out at regular intervals and when ash blockage is detected. This ensures that combustion is always perfect and efficient.

Go Fast



Das System besteht aus einer Zündkerze/Widerstand aus Keramik, die eine **schnellere Zündung der Pellets** und einen geringeren Stromverbrauch als herkömmliche Metallwiderstände gewährleistet. Diese Widerstandsart hat zudem eine längere Lebensdauer, da sie besser gegen Oxidation, sowie natürliche und chemische Korrosion beständig sind.

Le système se compose d'une bougie d'allumage/résistance en céramique qui garantit un **allumage plus rapide des pellets** et une consommation électrique plus faible que les résistances métalliques traditionnelles. Ce type de résistance a en outre une durée de vie plus longue, car elle résiste mieux à l'oxydation, ainsi qu'à la corrosion naturelle et chimique.

Sistema costituito da una candelella/resistenza di tipo ceramico che garantisce un' **accensione più rapida del pellet** e un consumo di elettricità inferiore rispetto alle tradizionali resistenze in metallo. Questa tipologia di resistenza ha inoltre una maggiore durata nel tempo grazie alla migliore tenuta all'ossidazione e alla corrosione naturale e chimica.

The system consists of a ceramic glow plug/resistor that ensures **faster pellet ignition** and lower power consumption than conventional metal resistors. This type of resistor also has a longer service life as they are better resistant to oxidation and to natural and chemical corrosion.

WiFi & Bluetooth



Mit der neuen **Easy Connect Plus App** und den integrierten **WLAN- und Bluetooth-**Technologien können Sie alle unsere Öfen direkt von Ihrem Smartphone aus steuern, wo immer Sie sich gerade befinden. Von einer einzigen Ansicht aus können Sie die Hauptfunktionen steuern und verwalten, die Betriebszeiten und die gewünschte Temperatur einstellen. So können Sie den Verbrauch optimieren und den Wärmekomfort nach Ihren Wünschen gestalten.

Grâce à la nouvelle application **Easy Connect Plus** et aux technologies **WiFi et Bluetooth** intégrées, vous pouvez contrôler tous nos poêles directement depuis votre smartphone, où que vous soyez. Une seule page vous permet de contrôler et gérer les fonctions principales, régler les durées et la température souhaitée, afin d'optimiser les consommations et améliorer le confort.

Con la nuova **Easy Connect Plus App** e le tecnologie **WiFi e Bluetooth** integrate, puoi controllare tutte le nostre stufe direttamente dal tuo smartphone, ovunque tu sia. In una sola schermata puoi controllare e gestire le funzioni principali, impostando tempi e temperatura desiderata per ottimizzare i consumi e migliorare il comfort.

With the new **Easy Connect Plus App** and the integrated **WiFi and Bluetooth** technologies, you can control all our stoves directly from your smartphone, wherever you are. From a single screen, you can access and control the main features and set on/off times and the desired temperature for optimal consumption and greater comfort.

Spirit 5
● 5,2 kW
P. 10



Sound 5/7 Ps
● 5,5/7 kW
P. 11



Sound 5/7 Up
● 5,5/7 kW
P. 11



Grace 7
● 7 kW
P. 12



Cristal 7/7 Up
● 7 kW
P. 12



Sweet 7
● 7 kW
P. 13



Perla 7
● 7 kW
P. 13



Cristal 9/Plus 9
● 8,5 kW
P. 14



Icon Plus 9
● 8,5 kW
P. 14



Quasimodo 9
● 9,3 kW
P. 15



Zefiro 9
● 9,3 kW
P. 15



Frame 9/9 Up
● 9,3 kW
P. 16



Shell 9 Up/Ps
● 9,1 kW
P. 16



Tile Plus 10
● 10 kW
P. 17



Wall Plus 10
● 10 kW
P. 17



Fenice 11/Plus 11
● 10,5 kW
P. 18



Prince 11/Plus 11
● 10,5 kW
P. 19



Kobe 11/Plus 11
● 10,5 kW
P. 19



Mithos P. 12/14 Ps
● 12/14 kW
P.20



Mithos P. 12/14 Up
● 12/14 kW
P.21



Atena Plus 12/14
● 12/14 kW
P.22



Idro Prince 12
● 11,8 kW
P.23



River idrotech
● 17,7/24,2 kW
P.24



Saturno 16/24
● 18/24,7 kW
P.25



Maya 16/24
● 16,2/22,8 kW
P.25



Idro Prince 30
● 28,6 kW
P.26



Smart 60/80
● 6,5/7,5 kW
P.27



Kook 60/80/90
● 6,2/ 7,5 kW
P.28



Spirit 5



5,2 kW

A+

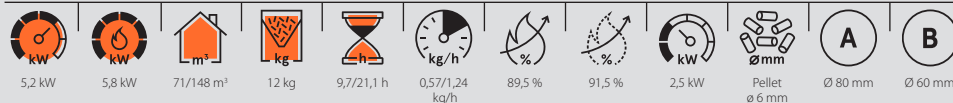

L 60 / P 27,5 / H 95,8 cm

Kg 55

HPOFSPTA15	Weiss / Blanc / Bianco / White	<input type="radio"/>
HPOFSPTA25	Rot / Rouge / Rosso / Red	<input checked="" type="radio"/>
HPOFSPTA35	Anthrazit / Anthracite / Antracite / Anthracite	<input type="radio"/>

Zubehör / Accessories / Accessori / Accessories (pag. 30-31)

Auf Anfrage / **Sur demande** / **Su richiesta** / **On request** Bogen 90° / Coude 90° / Curva 90° / Elbow 90°



Sound 5/7 Ps



Sound 5/7 Ps

5,5/7 kW

A+

5,5 7 (v.7) kW	6,1 7,7 (v.7) kW	71/157 71/200 (v.7) m³	11 kg	8,5/18,3 6,5/18,3 (v.7) h	0,6/1,3 0,6/1,7 (v.7) kg/h	90 %	91 %	2,5 kW	Pellet ø 6 mm	ø 80 mm	ø 60 mm



L 49,8 / P 54,8 / H 94,9 cm

Kg 76

HPOFSNDH35 **Sound 5 Ps** Anthrazit / Anthracite / Antracite / Anthracite

HPOFSNDH37 **Sound 7 Ps** Anthrazit / Anthracite / Antracite / Anthracite



Sound 5/7 Up

5,5/7 kW

A+

5,5 7 (v.7) kW	6,1 7,7 (v.7) kW	71/157 71/200 (v.7) m³	11 kg	8,5/18,3 6,5/18,3 (v.7) h	0,6/1,3 0,6/1,7 (v.7) kg/h	90 %	91 %	2,5 kW	Pellet ø 6 mm	ø 80 mm	ø 130 mm



L 49,8 / P 59,7 / H 94,9 cm

Kg 76

HPOFSNDO15 **Sound 5 Up** Weiss / Blanc / Bianco / White

HPOFSNDO75 Titan / Titane / Titanio / Titanium

HPOFSNDO35 Anthrazit / Anthracite / Antracite / Anthracite

HPOFSNDO17 **Sound 7 Up** Weiss / Blanc / Bianco / White

HPOFSNDO77 Titan / Titane / Titanio / Titanium

HPOFSNDO37 Anthrazit / Anthracite / Antracite / Anthracite



Grace 7

7 kW

A+

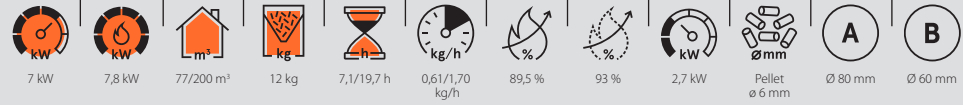

L 69 / P 27,3 / H 95,2 cm

Kg 63,5/72/80

HPOFGRCA97	Schwarzglas / Verre noir / Vetro nero / Black glass	
HPOFGRCA17	Weiss / Blanc / Bianco / White	
HPOFGRCA27	Rot / Rouge / Rosso / Red	
HPOFGRCA57	Hellbronze / Bronze clair / Bronzo chiaro / Light Bronze	
HPOFGRCA37	Anthrazit / Anthracite / Antracite / Anthracite	
HPOFGRCA87	Serpentinstein / Pierre Serpentine / Pietra Serpentino / Serpentine stone	

Zubehör / Accessories / Accessori / Accessories (pag. 30-31)

Auf Anfrage
Sur demande
Su richiesta
On request

Dekorativer Sockel / Socle décoratif / Piedistallo decorativo / Decorative stand
Wandhalterungs-Kit / Kit support mural / Kit supporto a parete / Wall support kit
Anschluss-Bogen 90° für Rauchgasauslass hinten/seitlich / Coude à 90° pour sortie des fumées arrière/laterale
/ Curva 90° per uscita fumi posteriore - laterale / Elbow 90° for smoke outlet rear/side



Cristal 7 / Cristal 7 Up

7 kW

A+

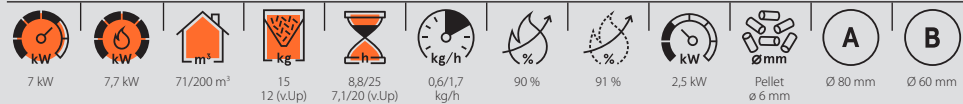

L 47,7 / P 45,4 / H 91/91,2 (v.Up) cm

Kg 65/56 (v.Up)

HPOFCSLH17	Cristal 7	Weiss / Blanc / Bianco / White	
HPOFCSLH27		Rot / Rouge / Rosso / Red	
HPOFCSLH37		Anthrazit / Anthracite / Antracite / Anthracite	
HPOFCSLO17	Cristal 7 Up	Weiss / Blanc / Bianco / White	
HPOFCSLO27		Rot / Rouge / Rosso / Red	
HPOFCSLO37		Anthrazit / Anthracite / Antracite / Anthracite	

Zubehör / Accessories / Accessori / Accessories (pag. 30-31)

Auf Anfrage
Sur demande
Su richiesta
On request

Anschluss "T" Ø 80 Rauchgasauslauf oben / Raccord "T" Ø 80 sortie supérieure / Raccordo "T" Ø 80 per uscita superiore /
Connection "T" Ø 80 top exhaust

Sweet 7



7 kW

A+

--	--	--	--	--	--	--	--	--	--	--	--



--	--	--	--	--	--	--	--

L 47 / P 45,2 / H 95 cm

Kg 56

HPOFSWTH17	Weiss / Blanc / Bianco / White	<input type="radio"/>
HPOFSWTH27	Rot / Rouge / Rosso / Red	<input checked="" type="radio"/>
HPOFSWTH37	Anthrazit / Anthracite / Antracite / Anthracite	<input type="radio"/>

Perla 7



7 kW

A+

--	--	--	--	--	--	--	--	--	--	--	--



--	--	--	--	--	--	--	--

L 52,1 / P 45,6 / H 94 cm

Kg 60/67

HPOFPRH107	Keramik Weiss / Céramique Blanc / Maiolica Bianco / White Majolica	<input type="radio"/>
HPOFPRH117	Keramik Elfenbein / Céramique Ivoire / Maiolica Avorio / Ivory Majolica	<input type="radio"/>
HPOFPRH127	Keramik Rot / Céramique Rouge / Maiolica Rosso / Red Majolica	<input checked="" type="radio"/>
HPOFPRH17	Weiss / Blanc / Bianco / White	<input type="radio"/>
HPOFPRH27	Rot / Rouge / Rosso / Red	<input checked="" type="radio"/>
HPOFPRH37	Anthrazit / Anthracite / Antracite / Anthracite	<input type="radio"/>

Cristal 9 / Cristal Plus 9



8,5 kW

A+

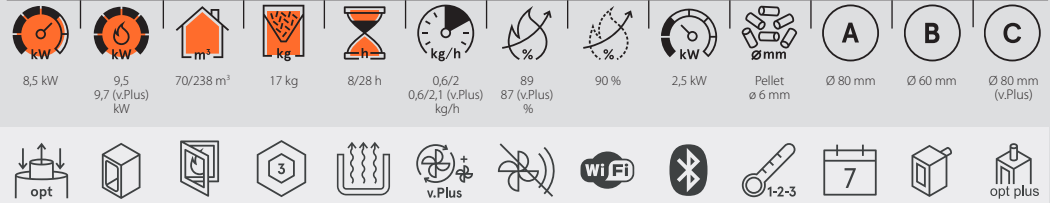

L 47,7 / P 46,3/53,8 / H 101,3 cm

Kg 70/ 75 kg (v.Plus)

HPOFCSLH18	Cristal 9	Weiss / Blanc / Bianco / White	<input type="radio"/>
HPOFCSLH28		Rot / Rouge / Rosso / Red	<input checked="" type="radio"/>
HPOFCSLH38		Anthrazit / Anthracite / Antracite / Anthracite	<input checked="" type="radio"/>
HPAPCSLH18	Cristal Plus 9	Weiss / Blanc / Bianco / White	<input type="radio"/>
HPAPCSLH28		Rot / Rouge / Rosso / Red	<input checked="" type="radio"/>
HPAPCSLH38		Anthrazit / Anthracite / Antracite / Anthracite	<input checked="" type="radio"/>

Zubehör / Accessories / Accessori / Accessories (pag. 30-31)

Auf Anfrage / **Sur demande** / **Su richiesta** / **On request**
 Abgasstutzen oben / Kit sortie fumée supérieur / Kit scarico superiore / Top exhaust kit
 Abgasstutzen oben konzentrisch / Kit sortie fumée supérieur concentrique / Kit scarico superiore concentrico / Top exhaust kit concentric
 Kanalisierungs-Kit oben / Kit canalisation supérieure / Kit canalizzazione superiore / Top ducting kit

Icon Plus 9



8,5 kW

A+

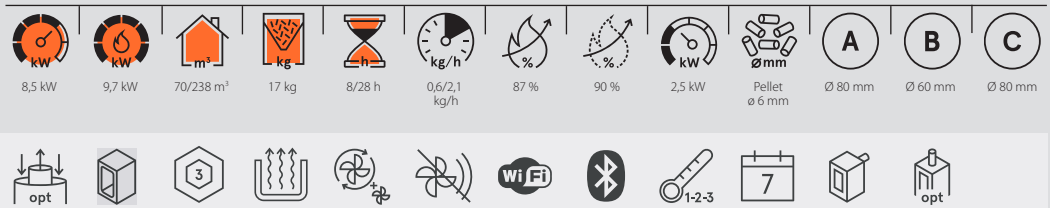

L 47,9 / P 53,3 / H 101,8 cm

Kg 87

HPAPICNH18		Weiss / Blanc / Bianco / White	<input type="radio"/>
HPAPICNH58		Hellbronze / Bronze clair / Bronzo chiaro / Light Bronze	<input checked="" type="radio"/>
HPAPICNH78		Titan / Titane / Titanio / Titanium	<input checked="" type="radio"/>
HPAPICNH28		Rot / Rouge / Rosso / Red	<input checked="" type="radio"/>
HPAPICNH38		Anthrazit / Anthracite / Antracite / Anthracite	<input checked="" type="radio"/>

Zubehör / Accessories / Accessori / Accessories (pag. 30-31)

Auf Anfrage / **Sur demande** / **Su richiesta** / **On request**
 Abgasstutzen oben / Kit sortie fumée supérieur / Kit scarico superiore / Top exhaust kit
 Abgasstutzen oben konzentrisch / Kit sortie fumée supérieur concentrique / Kit scarico superiore concentrico / Top exhaust kit concentric
 Kanalisierungs-Kit oben / Kit canalisation supérieure / Kit canalizzazione superiore / Top ducting kit

Quasimodo 9



9,3 kW

A+

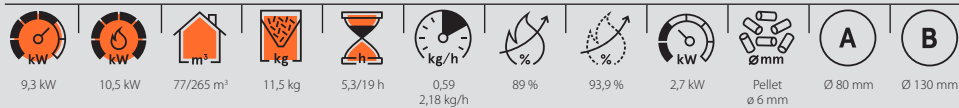

L 70 / P 58 / H 56 cm

Kg 95

HPOFQSMO49

Box Up

Schwarz/Noir/Nero/Black

HPOFQSMO49*S

Up

Schwarz/Noir/Nero/Black

Zefiro 9



9,3 kW

A+

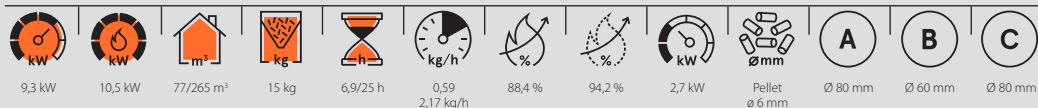

L 69,7 / P 55 / H 49 cm

Kg 94

HPCHEZFR49

Schwarzglas/Verre noir/Vetro nero/Black glass

Zubehör / Accessories / Accessori / Accessories (pag. 30-31)

HPCHZSOC4

Unterbau-Sockel / Soubassement / Sottostruttura / Substructure

PPCHZSCH4

Pellet-Schublade / Tiroir pour pellets / Cassetto pellet / Pellet drawer

PPCHZLKL4

Pellet-Lade-Klappe / Trappe chargement pellets / Portello carico pellet / Pellet loading hatch

PPCHZADR41

Rahmen / Cadre / Cornice / Frame – **792x561 mm**

PPCHZADR42

Rahmen (Schublade) / Cadre (tiroir) / Cornice (cassetto) / Frame (drawer) – **792x617 mm**

PPCHZKAN4

Kit für Kanalisierung / Kit canalisation / Kit canalizzazione / Ducting kit



Frame 9 / Frame 9 Up

9,3 kW

A+

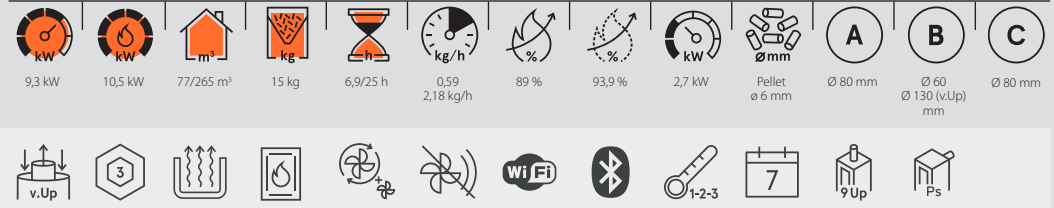

L 73,4 / P 53 / H 78 cm

Kg 105

HPOFFRMH59	Frame 9	Hellbronze / Bronze clair / Bronzo chiaro / Light Bronze	●
HPOFFRMH39		Anthrazit / Anthracite / Antracite / Anthracite	●
HPOFFRMH49		Schwarz / Noir / Nero / Black	●
HPOFFRMO59	Frame 9 Up	Hellbronze / Bronze clair / Bronzo chiaro / Light Bronze	●
HPOFFRMO39		Anthrazit / Anthracite / Antracite / Anthracite	●
HPOFFRMO49		Schwarz / Noir / Nero / Black	●

Zubehör / Accessories / Accessori / Accessories (pag. 30-31)

PPCHZKANFRM
PPCHZKLFRM

Kit für Kanalisierung / Kit de canalisation / Kit canalizzazione / Ducting kit
Pellet-Lade-Rutsche / Kit goulotte chargement pellets / Kit scivolo carico pellet / Pellet loading chute kit



Shell 9 Up / Shell 9 Ps

9,1 kW

A+

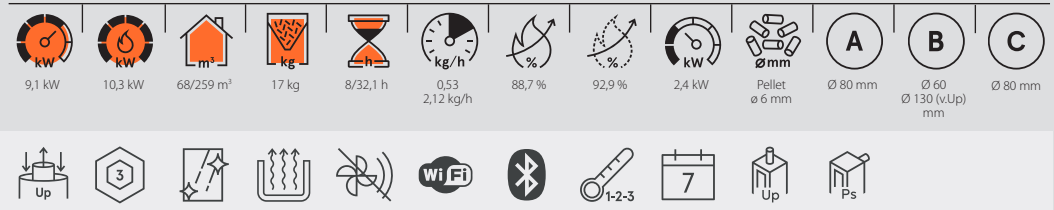

L 52,4 / P 59,2/55,6 (v.Up) / H 114 cm

Kg 85,3/88 (v.Up)

HPOFSHLO19	Shell 9 Up	Weiss / Blanc / Bianco / White	○
HPOFSHLO79		Titan / Titane / Titanio / Titanium	●
HPOFSHLO69		Dunkelbronze / Bronze foncé / Bronzo scuro / Dark Bronze	●
HPOFSHLO39		Anthrazit / Anthracite / Antracite / Anthracite	●
HPOFSHLH19	Shell 9 Ps	Weiss / Blanc / Bianco / White	○
HPOFSHLH79		Titan / Titane / Titanio / Titanium	●
HPOFSHLH69		Dunkelbronze / Bronze foncé / Bronzo scuro / Dark Bronze	●
HPOFSHLH39		Anthrazit / Anthracite / Antracite / Anthracite	●



Tile Plus 10

10 kW

A+



L 94,8 / P 26,5 / H 111,7 cm

Kg 130

HPAPTLEA10	Weiss / Blanc / Bianco / White	<input type="radio"/>
HPAPTLEA50	Hellbronze / Bronze clair / Bronzo chiaro / Light Bronze	<input type="radio"/>
HPAPTLEA70	Titan / Titane / Titanio / Titanium	<input type="radio"/>
HPAPTLEA20	Rot / Rouge / Rosso / Red	<input type="radio"/>
HPAPTLEA30	Anthrazit / Anthracite / Antracite / Anthracite	<input type="radio"/>

Zubehör / Accessories / Accessori / Accessories (pag. 30-31)

Auf Anfrage
Sur demande
Su richiesta
On request

Bogen 90° für seitliche Kanalisierung / Coude 90° pour canalisation latérale / Curva 90° per canalizzazione laterale / Elbow 90° for lateral ducting



Wall Plus 10

10 kW

A+

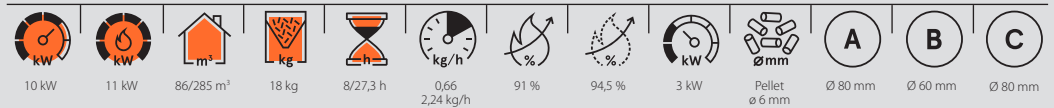

L 96,5 / P 30,4 / H 102,4 cm

Kg 103

HPAPWLLA10	Weiss / Blanc / Bianco / White	<input type="radio"/>
HPAPWLLA20	Rot / Rouge / Rosso / Red	<input type="radio"/>



Fenice 11 / Fenice Plus 11

10,5 kW

A+

10,5 kW	11,6 kW 12 (v.Plus) kW	84/294 m³	20 kg	8/29 h	0,7/2,5 kg/h	90	90 %	3 kW	Pellet Ø 6 mm	Ø 80 mm	Ø 60 mm	Ø 80 mm (v.Plus)

L 56,9 / P 51,2 / H 109 cm

Kg 130/133 (v.Plus)

HPOFFNCH11	Fenice 11	Weiss - Gold / Blanc - Or / Bianco - Oro / White - Gold	
HPOFFNCH71		Titan - Anthrazit / Titane - Anthracite / Titanio - Antracite / Titanium - Anthracite	
HPOFFNCH31		Anthrazit - Titan / Anthracite - Titane / Antracite - Titanio / Anthracite - Titanium	
HPAPFNCH11	F. Plus 11	Weiss - Gold / Blanc - Or / Bianco - Oro / White - Gold	
HPAPFNCH71		Titan - Anthrazit / Titane - Anthracite / Titanio - Antracite / Titanium - Anthracite	
HPAPFNCH31		Anthrazit - Titan / Anthracite - Titane / Antracite - Titanio / Anthracite - Titanium	

Zubehör / Accessories / Accessori / Accessories (pag. 30-31)

Auf Anfrage
Su demande
Su richiesta
On request

Abgasstutzen oben konzentrisch / Kit sortie fumée supérieur concentrique / Kit scarico superiore concentrico / Top exhaust kit concentric
Kanalierungs-Kit oben / Kit canalisation supérieure / Kit canalizzazione superiore / Top ducting kit





Prince 11 / Prince Plus 11

10,5 kW

A+

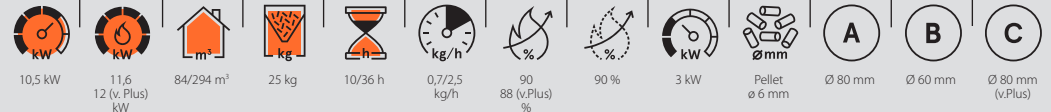

L 51,5 / P 54,7 / H 109,9 cm

Kg 109/112 (v.Plus)

HPOFPRCH71	Prince 11	Titan - Rahmen schwarz / Titane - cadre noir / Titanio - cornice nera / Titanium - black frame	●
HPOFPRCH51		Hellbronze - Rahmen schwarz / Bronze clair - cadre noir / Bronzo chiaro - cornice nera / Light Bronze - black frame	●
HPOFPRCH11		Weiss - Edelstahlrahmen / Blanc - cadre inox / Bianco - cornice inox / White - stainless steel frame	○
HPOFPRCH21		Rot - Edelstahlrahmen / Rouge - cadre inox / Rosso - cornice inox / Red - stainless steel frame	●
HPOFPRCH31		Anthrazit - Edelstahlrahmen / Anthracite - cadre inox / Antracite - cornice inox / Anthracite - stainless steel frame	●
HPAPPRCH71	P.Plus 11	Titan - Rahmen schwarz / Titane - cadre noir / Titanio - cornice nera / Titanium - black frame	●
HPAPPRCH51		Hellbronze - Rahmen schwarz / Bronze clair - cadre noir / Bronzo chiaro - cornice nera / Light Bronze - black frame	●
HPAPPRCH11		Weiss - Edelstahlrahmen / Blanc - cadre inox / Bianco - cornice inox / White - stainless steel frame	○
HPAPPRCH21		Rot - Edelstahlrahmen / Rouge - cadre inox / Rosso - cornice inox / Red - stainless steel frame	●
HPAPPRCH31		Anthrazit - Edelstahlrahmen / Anthracite - cadre inox / Antracite - cornice inox / Anthracite - stainless steel frame	●

Zubehör / Accessories / Accessori / Accessories (pag. 30-31)

**Auf Anfrage
Sur demande
Su richiesta
On request**

Abgasstutzen oben konzentrisch / Kit sortie fumée supérieur concentrique / Kit scarico superiore concentrico / Top exhaust kit concentric
Kanaliserungs-Kit oben / Kit canalisation supérieure / Kit canalizzazione superiore / Top ducting kit



Kobe 11 / Kobe Plus 11

10,5 kW

A+

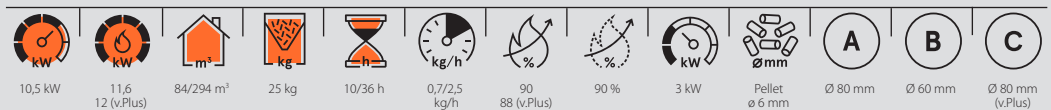

L 51,6 / P 55 / H 109,6 cm

Kg 111/114 (v.Plus)

HPOFKOBH11	Kobe 11	Weiss / Blanc / Bianco / White	○
HPOFKOBH51		Hellbronze / Bronze clair / Bronzo chiaro / Light Bronze	●
HPOFKOBH71		Titan / Titane / Titanio / Titanium	●
HPOFKOBH21		Rot / Rouge / Rosso / Red	●
HPOFKOBH31		Anthrazit / Anthracite / Antracite / Anthracite	●
HPAPKOBH11	Kobe Plus 11	Weiss / Blanc / Bianco / White	○
HPAPKOBH51		Hellbronze / Bronze clair / Bronzo chiaro / Light Bronze	●
HPAPKOBH71		Titan / Titane / Titanio / Titanium	●
HPAPKOBH21		Rot / Rouge / Rosso / Red	●
HPAPKOBH31		Anthrazit / Anthracite / Antracite / Anthracite	●

Zubehör / Accessories / Accessori / Accessories (pag. 30-31)

**Auf Anfrage
Sur demande
Su richiesta
On request**

Abgasstutzen oben konzentrisch / Kit sortie fumée supérieur concentrique / Kit scarico superiore concentrico / Top exhaust kit concentric
Kanaliserungs-Kit oben / Kit canalisation supérieure / Kit canalizzazione superiore / Top ducting kit

Mithos Plus 12/14 Ps

12/14 kW

A+

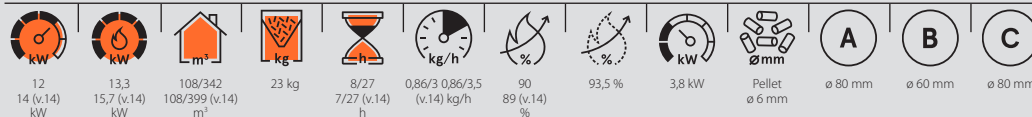

L 95 / P 44 / H 118,5 cm

Kg 161/191

HPAPMTHH12	Plus 12 Ps	Weiss/Blanc/Bianco/White	<input type="radio"/>
HPAPMTHH52		Hellbronze / Bronze clair / Bronzo chiaro / Light Bronze	<input type="radio"/>
HPAPMTHH72		Titan / Titane / Titanio / Titanium	<input type="radio"/>
HPAPMTHH82		Serpentinstein / Pierre Serpentino / Pietra Serpentino / Serpentine stone	<input type="radio"/>
HPAPMTHH22		Rot / Rouge / Rosso / Red	<input type="radio"/>
HPAPMTHH32		Anthrazit / Anthracite / Antracite / Anthracite	<input type="radio"/>
HPAPMTHH14	Plus 14 Ps	Weiss/Blanc/Bianco/White	<input type="radio"/>
HPAPMTHH54		Hellbronze / Bronze clair / Bronzo chiaro / Light Bronze	<input type="radio"/>
HPAPMTHH74		Titan / Titane / Titanio / Titanium	<input type="radio"/>
HPAPMTHH84		Serpentinstein / Pierre Serpentino / Pietra Serpentino / Serpentine stone	<input type="radio"/>
HPAPMTHH24		Rot / Rouge / Rosso / Red	<input type="radio"/>
HPAPMTHH34		Anthrazit / Anthracite / Antracite / Anthracite	<input type="radio"/>

Zubehör / Accessories / Accessori / Accessories (pag. 30-31)

Auf Anfrage
Sur demande
Su richiesta
On request

Bogen 90° für seitliche Kanalisierung / Coude 90° pour canalisation latérale / Curva 90° per canalizzazione laterale / Elbow 90° for lateral ducting



Mithos Plus 12/14 Up



12/14 kW

A+

12 14 (v.14) kW	13,3 15,7 (v.14) kW	108/342 108/399 (v.14) m³	23 kg	8/27 7/27 (v.14) h	0,86/3 0,86/3,5 (v.14) kg/h	90 89 (v.14) %	93,5 %	3,8 kW	Pellet ø 6 mm	ø 80 mm	ø 130 mm	ø 80 mm	



L 95 / P 44 / H 118,5 cm

Kg 165/195

HPAPMTH012	Plus 12 Up	Weiss / Blanc / Bianco / White	<input type="radio"/>
HPAPMTH052		Hellbronze / Bronze clair / Bronzo chiaro / Light Bronze	<input type="radio"/>
HPAPMTH072		Titan / Titane / Titanio / Titanium	<input type="radio"/>
HPAPMTH082		Serpentinstein / Pierre Serpentino / Pietra Serpentino / Serpentine stone	<input type="radio"/>
HPAPMTH022		Rot / Rouge / Rosso / Red	<input type="radio"/>
HPAPMTH032		Anthrazit / Anthracite / Antracite / Anthracite	<input type="radio"/>
HPAPMTH014	Plus 14 Up	Weiss / Blanc / Bianco / White	<input type="radio"/>
HPAPMTH054		Hellbronze / Bronze clair / Bronzo chiaro / Light Bronze	<input type="radio"/>
HPAPMTH074		Titan / Titane / Titanio / Titanium	<input type="radio"/>
HPAPMTH084		Serpentinstein / Pierre Serpentino / Pietra Serpentino / Serpentine stone	<input type="radio"/>
HPAPMTH024		Rot / Rouge / Rosso / Red	<input type="radio"/>
HPAPMTH034		Anthrazit / Anthracite / Antracite / Anthracite	<input type="radio"/>

Zubehör / Accessories / Accessori / Accessories (pag. 30-31)

Auf Anfrage
Sur demande
Su richiesta
On request

Bogen 90° für seitliche Kanalisierung / Coude 90° pour canalisation latérale / Curva 90° per canalizzazione laterale /
Elbow 90° for lateral ducting

Atena Plus 12/14



12/14 kW

A+

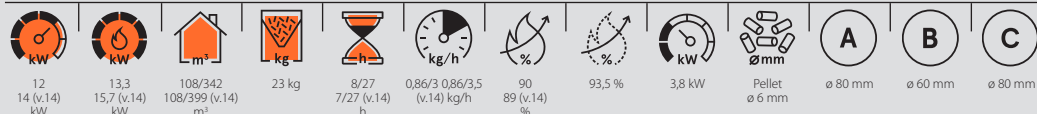

L 58 / P 58 / H 114 cm

Kg 152/160

HPAPATHN102	Plus 12	Keramik Weiss / Céramique Blanc / Maiolica Bianco / White Majolica	<input type="radio"/>
HPAPATHN112		Keramik Elfenbein / Céramique Ivoire / Maiolica Avorio / Ivory Majolica	<input type="radio"/>
HPAPATHN122		Keramik Rot / Céramique Rouge / Maiolica Rosso / Red Majolica	<input type="radio"/>
HPAPATHN12		Weiss / Blanc / Bianco / White	<input type="radio"/>
HPAPATHN02		Elfenbein / Ivoire / Avorio / Ivory	<input type="radio"/>
HPAPATHN72		Titan / Titane / Titanio / Titanium	<input type="radio"/>
HPAPATHN22		Rot / Rouge / Rosso / Red	<input type="radio"/>
HPAPATHN32		Anthrazit / Anthracite / Antracite / Anthracite	<input type="radio"/>
HPAPATHN104	Plus 14	Keramik Weiss / Céramique Blanc / Maiolica Bianco / White Majolica	<input type="radio"/>
HPAPATHN114		Keramik Elfenbein / Céramique Ivoire / Maiolica Avorio / Ivory Majolica	<input type="radio"/>
HPAPATHN124		Keramik Rot / Céramique Rouge / Maiolica Rosso / Red Majolica	<input type="radio"/>
HPAPATHN14		Weiss / Blanc / Bianco / White	<input type="radio"/>
HPAPATHN04		Elfenbein / Ivoire / Avorio / Ivory	<input type="radio"/>
HPAPATHN74		Titan / Titane / Titanio / Titanium	<input type="radio"/>
HPAPATHN24		Rot / Rouge / Rosso / Red	<input type="radio"/>
HPAPATHN34		Anthrazit / Anthracite / Antracite / Anthracite	<input type="radio"/>

Zubehör / Accessories / Accessori / Accessories (pag. 30-31)

Auf Anfrage
Sur demande
Su richiesta
On request

Kanalierungs-Kit oben / Kit canalisation supérieure / Kit canalizzazione superiore / Ducting kit top
Abgasstutzen oben konzentrisch / Kit sortie fumée supérieur concentrique / Kit scarico superiore concentrico / Top
exhaust kit concentric



Idro Prince 12

11,8 kW

A+

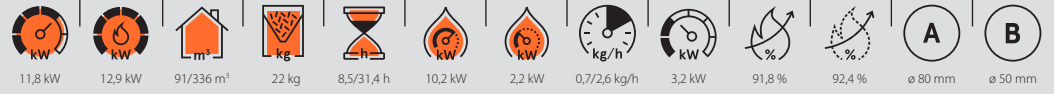

L 53,6 / P 56,2 / H 104,5 cm

Kg 132,1

HPHYPRCH12	Weiss / Blanc / Bianco / White	<input type="radio"/>
HPHYPRCH52	Hellbronze / Bronze clair / Bronzo chiaro / Light Bronze	<input type="radio"/>
HPHYPRCH72	Titan / Titane / Titanio / Titanium	<input type="radio"/>
HPHYPRCH22	Rot / Rouge / Rosso / Red	<input type="radio"/>
HPHYPRCH32	Anthrazit / Anthracite / Antracite / Anthracite	<input type="radio"/>



River idrotech 18/24/24 H2O



17,7/24,2 kW

A++

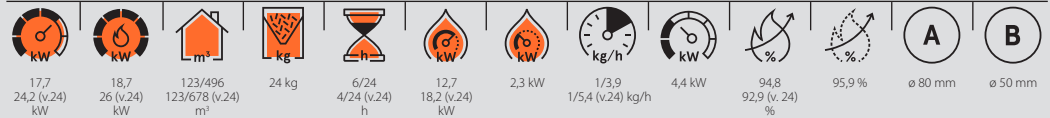

L 53 / P 51,7 / H 110,3 cm

Kg 136/167

HPHYVRH18	Idrotech 18	Weiss / Blanc / Bianco / White	<input type="radio"/>
HPHYVRH58		Hellbronze / Bronze clair / Bronzo chiaro / Light Bronze	<input type="radio"/>
HPHYVRH78		Titan / Titane / Titanio / Titanium	<input type="radio"/>
HPHYVRH38		Anthrazit / Anthracite / Antracite / Anthracite	<input type="radio"/>
HPHYVRH108		Keramik Weiss / Céramique Blanc / Maiolica Bianco / White Majolica	<input type="radio"/>
HPHYVRH128		Keramik Rot / Céramique Rouge / Maiolica Rosso / Red Majolica	<input type="radio"/>
HPHYVRH118		Keramik Elfenbein / Céramique Ivoire / Maiolica Avorio / Ivory Majolica	<input type="radio"/>
HPHYVRH14	Idrotech 24	Weiss / Blanc / Bianco / White	<input type="radio"/>
HPHYVRH54		Hellbronze / Bronze clair / Bronzo chiaro / Light Bronze	<input type="radio"/>
HPHYVRH74		Titan / Titane / Titanio / Titanium	<input type="radio"/>
HPHYVRH34		Anthrazit / Anthracite / Antracite / Anthracite	<input type="radio"/>
HPHYVRH104		Keramik Weiss / Céramique Blanc / Maiolica Bianco / White Majolica	<input type="radio"/>
HPHYVRH124		Keramik Rot / Céramique Rouge / Maiolica Rosso / Red Majolica	<input type="radio"/>
HPHYVRH114		Keramik Elfenbein / Céramique Ivoire / Maiolica Avorio / Ivory Majolica	<input type="radio"/>
HPHYWRH14	24 H₂O	Weiss / Blanc / Bianco / White	<input type="radio"/>
HPHYWRH54		Hellbronze / Bronze clair / Bronzo chiaro / Light Bronze	<input type="radio"/>
HPHYWRH74		Titan / Titane / Titanio / Titanium	<input type="radio"/>
HPHYWRH34		Anthrazit / Anthracite / Antracite / Anthracite	<input type="radio"/>
HPHYWRH104		Keramik Weiss / Céramique Blanc / Maiolica Bianco / White Majolica	<input type="radio"/>
HPHYWRH124		Keramik Rot / Céramique Rouge / Maiolica Rosso / Red Majolica	<input type="radio"/>
HPHYWRH114		Keramik Elfenbein / Céramique Ivoire / Maiolica Avorio / Ivory Majolica	<input type="radio"/>

Zubehör / Accessories / Accessori / Accessories (pag. 30-31)

Auf Anfrage
Sur demande
Su richiesta
On request

Snubber
NTC-Sonde / Sonde NTC / Sonda NTC / NTC probe
Antikondensationsventil / Valve anti-condensation / Valvola anticondensa / Anticondensation valve



Saturno 16/24

18/24,7 kW

A++

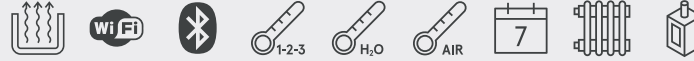
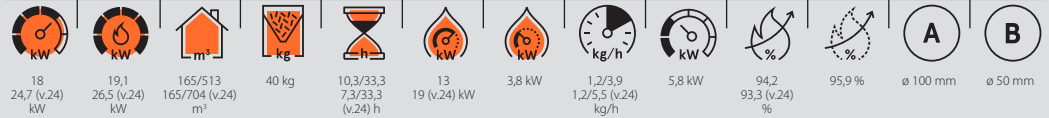

L 91,5 / P 62 / H 73 cm

Kg 230

HPCEHSTN48 **Saturno 16** Schwarz/Noir/Nero/Black ●

HPCEHSTN44 **Saturno 24** Schwarz/Noir/Nero/Black ●

Zubehör / Accessories / Accessori / Accessories (pag. 30-31)

HPCHZSOC4 Unterbau-Sockel / Soubassement / Sottostruttura / Substructure



Maya 16/24

16,2/22,8kW

A+

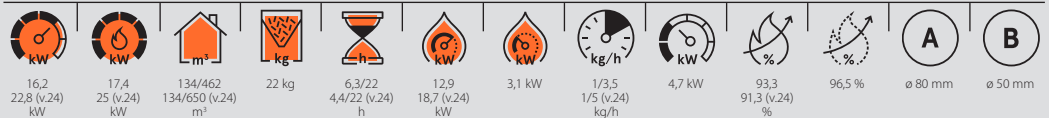

L 92,5 / P 46,5 / H 113,5 cm

Kg 167

HPHYMYAN16 **Maya 16** Weiss/Blanc/Bianco/White ○

HPHYMYAN56 Hellbronze / Bronze clair / Bronzo chiaro / Light Bronze ●

HPHYMYAN76 Titan / Titane / Titanio / Titanium ●

HPHYMYAN26 Rot / Rouge / Rosso / Red ●

HPHYMYAN36 Anthrazit / Anthracite / Antracite / Anthracite ●

HPHYMYAN12 **Maya 24** Weiss/Blanc/Bianco/White ○

HPHYMYAN52 Hellbronze / Bronze clair / Bronzo chiaro / Light Bronze ●

HPHYMYAN72 Titan / Titane / Titanio / Titanium ●

HPHYMYAN22 Rot / Rouge / Rosso / Red ●

HPHYMYAN32 Anthrazit / Anthracite / Antracite / Anthracite ●

Idro Prince 30

28,6 kW

A+

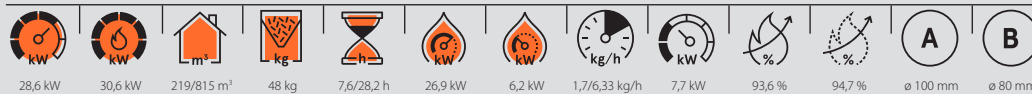

L 68,6 / P 77,7 / H 137,2 cm

Kg 265

HPHYPRCH18

Weiss / Blanc / Bianco / White



HPHYPRCH28

Rot / Rouge / Rosso / Red



Smart 60/80



6,5/7,7 kW

A+

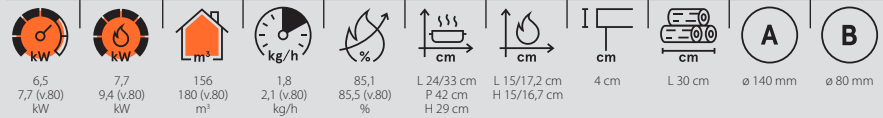

L 59,5/89,5 / P 60 / H 86 cm

Kg 123/152

HHERSMTNE6	Smart 60	Edelstahl / Acier Inox / Acciaio Inox / Stainless steel	<input type="radio"/>
HHERSMTN36		Anthrazit / Anthracite / Antracite / Anthracite	<input checked="" type="radio"/>
HHERSMTN16		Weiss / Blanc / Bianco / White	<input type="radio"/>
HHERSMTN26		Rot / Rouge / Rosso / Red	<input checked="" type="radio"/>
HHERSMTNE6*E	60 vent.	Edelstahl (Lüftung) / Acier Inox (ventilation) / Acciaio Inox (ventilazione) / Stainless steel (ventilation)	<input type="radio"/>
HHERSMTN36*E		Anthrazit (Lüftung) / Anthracite (ventilation) / Antracite (ventilazione) / Anthracite (ventilation)	<input checked="" type="radio"/>
HHERSMTN16*E		Weiss (Lüftung) / Blanc (ventilation) / Bianco (ventilazione) / White (ventilation)	<input type="radio"/>
HHERSMTN26*E		Rot (Lüftung) / Rouge (ventilation) / Rosso (ventilazione) / Red (ventilation)	<input checked="" type="radio"/>
HHERSMTNE8	Smart 80	Edelstahl / Acier Inox / Acciaio Inox / Stainless steel	<input type="radio"/>
HHERSMTN38		Anthrazit / Anthracite / Antracite / Anthracite	<input checked="" type="radio"/>
HHERSMTN18		Weiss / Blanc / Bianco / White	<input type="radio"/>
HHERSMTN28		Rot / Rouge / Rosso / Red	<input checked="" type="radio"/>
HHERSMTNE8*E	80 vent.	Edelstahl (Lüftung) / Acier Inox (ventilation) / Acciaio Inox (ventilazione) / Stainless steel (ventilation)	<input type="radio"/>
HHERSMTN38*E		Anthrazit (Lüftung) / Anthracite (ventilation) / Antracite (ventilazione) / Anthracite (ventilation)	<input checked="" type="radio"/>
HHERSMTN18*E		Weiss (Lüftung) / Blanc (ventilation) / Bianco (ventilazione) / White (ventilation)	<input type="radio"/>
HHERSMTN28*E		Rot (Lüftung) / Rouge (ventilation) / Rosso (ventilazione) / Red (ventilation)	<input checked="" type="radio"/>

Zubehör / Accessories / Accessori / Accessories

HHZSMTFU	Smart 60/80	Füsse / Pieds / Piedini / Feet
HHZUNI45		Herd-Anschluss univ. Ø140/150 / Raccord cuisinière univ. Ø140/150 / Raccordo cucina univ. Ø140/150 / Cooker connection univ. Ø140/150
HHZSMTS06	Smart 60	Sockel Edelstahl Smart 60 / Socle Inox Smart 60 / Zoccolo Inox Smart 60 / Podium stainless Smart 60
HHZSMTWB46		Wandblende H4 Smart 60 / Bord relevé H4 Smart 60 / Alzatina H4 Smart 60 / Raised border H4 Smart 60
HHZSMTWB66		Wandblende H6 Smart 60 / Bord relevé H6 Smart 60 / Alzatina H6 Smart 60 / Raised border H6 Smart 60
HHZSMTKD6		Abdeckung Smart 60 / Couvercle Smart 60 / Coperchio Smart 60 / Cover Smart 60
HHZSMTS08	Smart 80	Sockel Edelstahl Smart 80 / Socle Inox Smart 80 / Zoccolo Inox Smart 80 / Podium stainless Smart 80
HHZSMTWB48		Wandblende H4 Smart 80 / Bord relevé H4 Smart 80 / Alzatina H4 Smart 80 / Raised border H4 Smart 80
HHZSMTWB68		Wandblende H6 Smart 80 / Bord relevé H6 Smart 80 / Alzatina H6 Smart 80 / Raised border H6 Smart 80
HHZSMTKD8		Abdeckung Smart/Kook 80 / Couvercle Smart/Kook 80 / Coperchio Smart/Kook 80 / Cover Smart/Kook 80



Kook 60/80/90

6,2/7,5 kW

A+

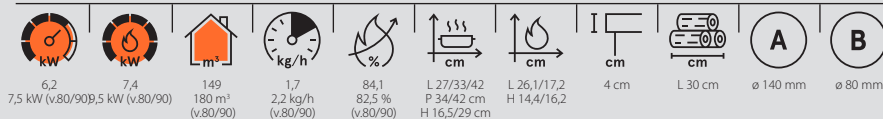

L 60/80/90 / P 60 / H 89,5 cm

Kg 121,6/138,2/147,2

HHERKOKNE6	Kook 60 4.0	Edelstahl / Acier Inox / Acciaio Inox / Stainless steel	<input type="radio"/>
HHERKOKN36		Anthrazit / Anthracite / Antracite / Anthracite	<input checked="" type="radio"/>
HHERKOKN16		Weiss / Blanc / Bianco / White	<input type="radio"/>
HHERKOKN46		Schwarz / Noir / Nero / Black	<input checked="" type="radio"/>
HHERKOKNE6*E	60 vent.	Edelstahl (Lüftung) / Acier Inox (ventilation) / Acciaio Inox (ventilazione) / Stainless steel (ventilation)	<input type="radio"/>
HHERKOKN36*E		Anthrazit (Lüftung) / Anthracite (ventilation) / Antracite (ventilazione) / Anthracite (ventilation)	<input checked="" type="radio"/>
HHERKOKN16*E		Weiss (Lüftung) / Blanc (ventilation) / Bianco (ventilazione) / White (ventilation)	<input type="radio"/>
HHERKOKN46*E		Schwarz (Lüftung) / Noir (ventilation) / Nero (ventilazione) / Black (ventilation)	<input checked="" type="radio"/>



HHERKOKNE8	Kook 80	Edelstahl / Acier Inox / Acciaio Inox / Stainless steel	<input type="radio"/>
HHERKOKN38		Anthrazit / Anthracite / Antracite / Anthracite	<input checked="" type="radio"/>
HHERKOKN18		Weiss / Blanc / Bianco / White	<input type="radio"/>
HHERKOKN48		Schwarz / Noir / Nero / Black	<input checked="" type="radio"/>
HHERKOKNE8*E	80 vent.	Edelstahl (Lüftung) / Acier Inox (ventilation) / Acciaio Inox (ventilazione) / Stainless steel (ventilation)	<input type="radio"/>
HHERKOKN38*E		Anthrazit (Lüftung) / Anthracite (ventilation) / Antracite (ventilazione) / Anthracite (ventilation)	<input checked="" type="radio"/>
HHERKOKN18*E		Weiss (Lüftung) / Blanc (ventilation) / Bianco (ventilazione) / White (ventilation)	<input type="radio"/>
HHERKOKN48*E		Schwarz (Lüftung) / Noir (ventilation) / Nero (ventilazione) / Black (ventilation)	<input checked="" type="radio"/>

HHERKOKNE9	Kook 90 4.0	Edelstahl / Acier Inox / Acciaio Inox / Stainless steel	<input type="radio"/>
HHERKOKN39		Anthrazit / Anthracite / Antracite / Anthracite	<input checked="" type="radio"/>
HHERKOKN19		Weiss / Blanc / Bianco / White	<input type="radio"/>
HHERKOKN49		Schwarz / Noir / Nero / Black	<input checked="" type="radio"/>
HHERKOKNE9*E	90 vent.	Edelstahl (Lüftung) / Acier Inox (ventilation) / Acciaio Inox (ventilazione) / Stainless steel (ventilation)	<input type="radio"/>
HHERKOKN39*E		Anthrazit (Lüftung) / Anthracite (ventilation) / Antracite (ventilazione) / Anthracite (ventilation)	<input checked="" type="radio"/>
HHERKOKN19*E		Weiss (Lüftung) / Blanc (ventilation) / Bianco (ventilazione) / White (ventilation)	<input type="radio"/>
HHERKOKN49*E		Schwarz (Lüftung) / Noir (ventilation) / Nero (ventilazione) / Black (ventilation)	<input checked="" type="radio"/>

Zubehör / Accessories / Accessori / Accessories

HHZKOKKD6	Abdeckung Kook 60 / Couvercle Kook 60 / Coperchio Kook 60 / Cover Kook 60
HHZSMTKD8	Abdeckung Smart/Kook 80 / Couvercle Smart/Kook 80 / Coperchio Smart/Kook 80 / Cover Smart/Kook 80



ICON 9 Plus

Zubehör • Accessories

Accessori • Accessories



Auf Anfrage • Sur demande
Su richiesta • On request

Bogen 90°
Coude 90°
Curva 90°
Elbow 90°



Auf Anfrage • Sur demande
Su richiesta • On request

Anschluss "T" Auslass oben
Raccord "T" sortie supérieure
Raccordo "T" uscita superiore
Connection "T" top exhaust
(Ø 80)



Auf Anfrage • Sur demande
Su richiesta • On request

Abgasstutzen oben
Kit sortie fumée supérieur
Kit scarico superiore
Top exhaust kit



Auf Anfrage • Sur demande
Su richiesta • On request

Abgasstutzen oben konzentrisch
Kit sortie fumée supérieur
concentrique
Kit scarico superiore concentrico
Top exhaust kit concentric



Auf Anfrage • Sur demande
Su richiesta • On request

Abgasstutzen oben konzentrisch
Kit sortie fumée supérieur
concentrique
Kit scarico superiore concentrico
Top exhaust kit concentric



Auf Anfrage • Sur demande
Su richiesta • On request

Kanalierungs-Kit oben
Kit canalisation supérieure
Kit canalizzazione superiore
Top ducting kit



PPCHZKAN4

Kit für Kanalisierung
Kit canalisation
Kit canalizzazione
Ducting kit



PPCHZKANFRM

Kit für Kanalisierung
Kit de canalisation
Kit canalizzazione
Ducting kit



**Auf Anfrage • Sur demande
Su richiesta • On request**

Bausatz konzentrisch oben
Kit concentrique supérieure
Kit concentrico superiore
Top concentric kit



**Auf Anfrage • Sur demande
Su richiesta • On request**

Anschluss konzentrisch
Raccord concentrique
Raccordo concentrico
Concentric connection
(Ø 80 fem./Ø 130 fem.)
(80 F - 130 F)



HPURECO

Fernbedienung
Télécommande
Telecomando
Remote Control

easy
connect/plus



HPUWIFI

Wi-Fi für alle Modelle vor dem integrierten Wi-Fi
Wi-Fi pour tous les modèles avant le Wi-Fi intégré
Wi-Fi per tutti i modelli precedenti al Wi-Fi integrato
Wi-Fi kit for all models prior to the integrated Wi-Fi



**Auf Anfrage • Sur demande
Su richiesta • On request**

Dekorativer Sockel
Socle décoratif
Piedistallo decorativo
Decorative stand



**Auf Anfrage • Sur demande
Su richiesta • On request**

Wandhalterungs-Kit
Kit support mural
Kit supporto a parete
Wall support kit



HPCHZSOC4

Unterbau-Sockel
Soubassement
Sottostruttura
Substructure



PPCHZSCH4

Pellet-Schublade
Tiroir pour pellets
Cassetto pellet
Pellet drawer



PPCHZLKL4

Pellet-Lade-Klappe
Trappe chargement pellets
Portello carico pellet
Pellet loading hatch



PPCHZADR41

Rahmen
Cadre
Cornice
Frame
792x561 mm



PPCHZADR42

Rahmen (Schublade)
Cadre (tiroir)
Cornice (cassetto)
Frame (drawer)
792x617 mm



PPCHZLKLFRM

Pellet-Lade-Rutsche
Kit goulotte chargement pellets
Kit scivolo carico pellet
Pellet loading chute kit

Allgemeine Verkaufs- und Lieferbedingungen

1. Allgemeines

Für den Geschäftsverkehr mit der Almeva AG gelten vorbehaltlich abweichender Angaben in der Auftragsbestätigung, ausschliesslich die nachstehenden Verkaufs- und Lieferbedingungen. Anders lautende Vereinbarungen, Abreden und Zusicherungen jeder Art sind nur gültig, wenn sie von der Almeva AG schriftlich bestätigt sind. Abweichende Geschäftsbedingungen des Vertragspartners sind selbst dann nicht anwendbar, wenn sie unwidersprochen sind.

2. Angebot und Preise

Alle Angebote sind freibleibend und unverbindlich. Die Preise verstehen sich grundsätzlich ab Werk zuzüglich ges. MwSt. Bei Einhaltung des Lieferplanes gelten die Preise ab einem Warenwert von Fr. 1'000.-- frei Haus. Sonst gilt ein Mindest-Rechnungsbetrag von Fr. 2'500.--. Bei Kleinmengen bis zu Fr. 50.-- Warenwert kann ein Kleinmengenzuschlag von Fr. 20.-- verrechnet werden. Die Abbildungen, Mass- und Gewichtsangaben in Katalogen und Listen der Almeva AG sind unverbindlich. Angebotsunterlagen, Entwürfe, Kostenvorschläge usw. sind Eigentum der Almeva AG. Sie dürfen ohne Zustimmung der Almeva AG weder vervielfältigt noch Dritten zugänglich gemacht werden.

3. Bestellung / Bestellungsverwicklung

Nur durch klare und eindeutige Bestellungen können Falschliefungen vermieden werden. Der Kunde ist deshalb angehalten, die Teile durch Angabe der Artikel-Nummer zu bestellen. Ohne diese Identifikation lehnt Almeva die Garantie für fehlerfreie Lieferungen ab.

4. Liefertermine

Die von Almeva AG bestätigten Liefertermine sind verbindlich. Wird ein Liefertermin um mehr als 30 Tage überschritten, so ist der Kunde nach Ansetzen einer angemessenen Nachfrist berechtigt, vom Vertrag zurückzutreten. Andere Ansprüche wegen Lieferverzögerungen sind ausgeschlossen.

5. Lieferung

Die Almeva AG wählt nach Möglichkeit die günstigste Lieferart. Für Expresslieferungen wird ein Zuschlag von Fr. 25.-- verrechnet. Verpackungen werden nicht zurückgenommen. Sofern der Kunde zu seinen Lasten den Abschluss einer Transportversicherung wünscht, muss er die Almeva AG hierfür schriftlich beauftragen.

6. Zahlungsbedingungen

Bei der Zahlung der Rechnungen innert 10 Tagen kann ein Skonto von 2% des Rechnungsbetrages exkl. MwSt. abgezogen werden. Andernfalls sind die Rechnungen innert 30 Tagen zu bezahlen. Unberechtigte Skontoabzüge werden nachbelastet. Ab Fälligkeitstag werden unter Vorbehalt der Geltendmachung weiteren Verzugschadens Verzugszinsen in der Höhe von 8% p.a. berechnet. Die gelieferte Ware bleibt bis zur vollständigen Bezahlung des entsprechenden Rechnungsbetrages Eigentum der Almeva AG.

7. Gewährleistung

Die Almeva AG leistet Gewähr dafür, dass die gelieferte Ware mangelfrei ist. Die Gewährleistungsfrist beträgt 12 Mte. ab Lieferung. Der Besteller hat die Ware sofort nach Erhalt zu prüfen und allfällige Mängel unverzüglich schriftlich zu rügen, ansonsten die Ware als genehmigt gilt. Bei Mängeln wird die Almeva AG ihrer Wahl nach, (a) die mangelhafte Ware ersetzen oder nachbessern, (b) den Kaufpreis für die mangelhafte Ware zurückerstatten. Weitere aus Mängeln der Ware hergeleitete Ansprüche stehen dem Besteller nicht zu.

8. Haftungsbeschränkung

Die Gewährleistungspflichten der Almeva AG sind in Ziffer 7 abschliessend geregelt. In keinem Fall hat der Besteller Anspruch auf Ersatz von Schäden, die nicht am Liefergegenstand selbst aufgetreten sind, wie namentlich Produktionsmängel, Produktionsausfälle, Nutzungsverluste, entgangener Gewinn, sowie anderen mittelbaren oder unmittelbaren Schaden.

Die Gewährleistung ist ausgeschlossen im Fall:

- natürlicher Abnutzung
- bei ungeeigneter oder unsachgemässer Verwendung oder Brennstoffen
- fehlerhafter Auslegung oder Montage
- bei übermässiger Beanspruchung
- bei äusseren Einflüssen
- fehlender oder unsachgemässer Wartung
- im Fall der Vornahme von Nachbesserungsarbeiten seitens des Kunden oder durch Dritte ohne Einwilligung der Almeva AG.

9. Exportverbot USA / Kanada

Der Besteller verpflichtet sich, die Ware (separat oder in Verbindung mit anderen Produkten) nicht nach USA oder Kanada zu exportieren.

10. Anwendbares Recht

Die Rechtsbeziehung zwischen Almeva AG und dem Besteller unterstehen dem Schweiz. Recht. Das Wiener Kaufrechtsabkommen (UN-Kaufrecht) findet keine Anwendung.

11. Erfüllungsort und Gerichtsstand

Erfüllungsort und Gerichtsstand ist Bischofszell, Schweiz. Die Almeva AG ist jedoch berechtigt, den Besteller auch an dessen Sitz zu belangen.

Conditions générales

1. Conditions générales

Pour toute transaction commerciale avec Almeva AG, et sans indication contraire, application exclusivement des conditions ci-dessous. Tout autre accord n'est valable que s'il est confirmé par la société Almeva AG. Les conditions divergentes du partenaire contractuel ne sont pas applicables même non contredites.

2. Offres et prix

Toutes nos offres sont indépendantes et non cumulables. Nos prix s'entendent départ usine Hors Taxes. Nous accordons une livraison Franco de port à partir d'un montant d'achat de Fr. 1'000.-- dans le cadre de notre planning hebdomadaire de livraison. Hors planning ce montant sera de Fr. 2'500.--. Pour des commandes inférieures à Fr. 50.--, un supplément de Fr. 20.-- peut être facturé. Les illustrations, dimensions et poids des catalogues et listes d'Almeva AG sont sans engagement. Les documents d'offre, les projets, les estimations de coûts, etc. sont la propriété d'Almeva AG. Ils ne peuvent être reproduits ou mis à la disposition de tiers sans l'accord de Almeva AG.

3. Commandes / Gestion des commandes

Seules les commandes claires et sans ambiguïté peuvent éviter les livraisons incorrectes. Le client est donc invité à commander les pièces en indiquant le numéro de l'article. Sans cette identification Almeva ne peut pas garantir des livraisons sans erreur.

4. Délais de livraison

Les dates de livraison confirmée par Almeva AG

engagent la société. Si une date de livraison est dépassée de plus de 30 jours, le client a droit, après avoir fixé une prolongation raisonnable, de se retirer du contrat. Toutes autres créances en raison de retards de livraison sont exclues.

5. Livraison

Almeva AG sélectionne le type de livraison le plus favorable. Pour les livraisons express, il sera facturé un supplément de Fr. 25.--. Les emballages ne sont pas repris. Si le client souhaite souscrire une assurance transport à ses frais, il doit en donner l'ordre écrit à Almeva AG.

6. Conditions de paiement

En cas de paiement dans un délai de 10 jours, nous accordons un escompte de 2% du montant de la facture, hors TVA. En cas contraire, les factures doivent être payées dans 30 jours. Les déductions d'escompte non autorisés seront facturés ultérieurement. A partir de la date d'échéance, des intérêts moratoires de 8% par an seront facturés, sous réserve de l'exercice du recours à d'autres dommages et intérêts pour demeure. Les marchandises livrées restent propriété de Almeva AG jusqu'au paiement intégral de la facture correspondante.

7. Garantie

Almeva AG garantit que les marchandises livrées sont exemptes de défauts. La période de garantie est de 12 mois à compter de la livraison. L'acheteur doit inspecter la marchandise immédiatement après réception et aviser immédiatement les défauts par écrit, sinon la marchandise sera considérée comme approuvée. En cas de défauts Almeva choisira, (a) remplacer les produits défectueux ou la réparation, (b) la restitution de prix d'achat des biens défectueux. L'acheteur n'aura pas d'autres revendications pour les défauts de la marchandise.

8. Limitation de responsabilité

Les obligations de garantie de Almeva AG sont exhaustivement couvertes au paragraphe 7. En aucun cas, le client a droit à une indemnisation pour les dommages qui ne sont pas survenus sur l'objet même de la livraison, tels que des défauts de production, perte de production, perte d'usage, perte de profit et d'autres dommages directs ou indirects. Cette exclusion ne concerne pas l'intention ou de négligence grave de Almeva AG, mais pour faute grave ou intentionnelle de personnes de Almeva.

La garantie est exclue en cas de:

- Usure naturelle
- En cas d'utilisation inappropriée ou combustibles inappropriés
- Conception ou assemblage incorrect
- Dans le cas d'une utilisation excessive
- En cas d'influences externes
- Maintenance manquante ou incorrecte
- Si le client ou un tiers effectue des travaux de réparation sans le consentement d'Almeva AG.

9. Interdiction des exportations États-Unis / Canada

L'acheteur accepte ne pas exporter les marchandises (séparément ou conjointement avec d'autres produits) vers les États-Unis ou au Canada.

10. Législation applicable

Les relations juridiques entre Almeva AG et le client sont soumis au droit suisse. La Convention de Vienne (CVM) n'est pas applicable.

11. Lieu de juridiction

Le siège juridique est Bischofszell, Suisse. Cependant Almeva AG se réserve toutefois la possibilité d'assigner au domicile de l'acheteur.

Termini e condizioni generali

1. Generalità

Per le transazioni commerciali con Almeva AG si applicano, esclusivamente i seguenti termini e condizioni. Accordi, intese e assicurazioni di qualsiasi tipo sono validi solo se confermati per iscritto da Almeva AG. Diversi termini e condizioni applicate dal contraente non saranno riconosciute se non preventivamente concordate.

2. Preventivi e prezzi

Le offerte si ritengono sempre formulate senza impegno. I prezzi si intendono franco fabbrica, IVA esclusa. In conformità con il piano di consegna concordato, la resa sarà porto franco per importi netti superiori a Fr. 1'000.--. Diversamente l'importo minimo sarà di Fr. 2'500.--. Per ordini fino a Fr. 50.--, potrà essere applicato un extra di Fr. 20.--.

Le illustrazioni, le dimensioni e le indicazioni di peso nei cataloghi e negli elenchi di Almeva AG non sono vincolanti. I documenti d'offerta, le bozze, le stime dei costi ecc. sono di proprietà della Almeva AG. Non possono essere riprodotti o messi a disposizione di terzi senza il consenso di Almeva AG.

3. Ordine / Gestione dell'ordine

Solo con ordini chiari ed univoci si eviteranno consegne errate. Il cliente è quindi invitato ad ordinare indicando il codice dell'articolo. Senza questa identificazione Almeva non può garantire consegne senza errori.

4. Data di consegna

La data di consegna confermata da Almeva AG è da ritenersi puramente indicativa e non tassativa. Qualora supererà i 30 giorni, il cliente avrà diritto, previa una proroga concordata, alla rescissione della commessa. Altre pretese, indennizzi o riserve a riguardo non saranno contemplate.

5. Consegna

Almeva AG sceglierà il tipo di consegna più favorevole possibile. Per le consegne espresse sarà addebitato un supplemento di Fr. 25.--. Gli imballaggi non possono essere restituiti.

Se il cliente desidera stipulare un'assicurazione sul trasporto a proprie spese, deve darne comunicazione scritta alla Almeva AG.

6. Condizioni di pagamento

In caso di pagamento entro 10 giorni, sarà concesso uno sconto del 2% sull'importo della fattura, IVA esclusa, che potrà essere dedotto. Diversamente le fatture dovranno essere pagate entro 30 giorni. Detrazioni di sconto non autorizzate verranno addebitate in seguito. A partire dalla data di scadenza verranno addebitati interessi pari al 8% annuo, come oggetto richiesto ad ulteriori danni. La merce consegnata rimane proprietà di Almeva AG fino al completo pagamento della fattura corrispondente.

7. Garanzia

Almeva AG garantisce che le merci consegnate sono prive di difetti. Il periodo di garanzia è di 12 mesi dalla consegna. L'acquirente dovrà controllare la merce immediatamente dopo il ricevimento e comunicarne tempestivamente eventuali difetti per iscritto; altrimenti la merce sarà considerata accettata. In caso di difetti Almeva AG sceglierà di: (a) sostituire la merce difettosa o la riparazione della stessa; (b) restituire al prezzo di acquisto la merce difettosa. Non saranno accettati successivamente ulteriori reclami da parte dell'acquirente.

8. Limitazione della responsabilità

Gli obblighi di garanzia di Almeva AG sono esaustivamente coperti nel paragrafo 7. In nessun caso il cliente ha diritto al risarcimento dei danni che non si siano riscontrati al momento della fornitura stessa, come difetti di produzione, la produzione perduta, perdita di utilizzo, perdita di profitto e altri danni diretti o indiretti. Ad esclusione delle ipotesi di dolo o colpa grave, in nessun caso ALMEVA

risponderà per danni a persone o a cose derivanti dall'uso del prodotto fornito.

La garanzia è esclusa in caso di:

- usura naturale
- in caso di inadatto o improprio uso o combustibili
- progettazione o montaggio non corretti
- in caso di uso eccessivo
- in caso influenze esterne
- mancanza di manutenzione o manutenzione impropria
- in caso di lavori di rettifica eseguiti dal cliente o da terzi senza il consenso di Almeva AG.

9. Divieto delle esportazioni negli Stati Uniti e Canada

All'acquirente si impone di non esportare i prodotti Almeva (separatamente o in combinazione con altri) negli Stati Uniti e Canada.

10. Legge applicabile

I rapporti giuridici tra Almeva AG e il cliente sono soggetti al diritto svizzero. La Convenzione di Vienna (CISG) non si applica.

11. Tribunale competente

Il foro competente è quello di Bischofszell, Svizzera. Tuttavia Almeva AG ha il diritto di citare in giudizio il cliente al suo domicilio.

General terms and conditions of sales and delivery

1. General

Unless otherwise stated in the order confirmation, the following terms and conditions of sale and delivery shall apply exclusively to business transactions with Almeva AG. Different agreements, understandings and assurances of any kind are only valid if they have been confirmed in writing by Almeva AG. Deviating terms and conditions of the contractual partner are not applicable even if they are not contradicted.

2. Offer and Prices

All offers are subject to change and non-binding. The prices are always ex works statutory VAT. If the delivery schedule is adhered to, the prices shall apply free domicile from a goods value of CHF 1'000.--. Otherwise, a minimum invoice amount of CHF 2'500.-- shall apply. For small quantities up to Fr. 50.--, a small quantity surcharge of Fr. 20.-- can be charged. The illustrations, dimensions and weight specifications in catalogues and lists of Almeva AG are non-binding. Quotation documents, drafts, cost estimates etc. are the property of Almeva AG. They may not be reproduced or made accessible to third parties without the consent of Almeva AG.

3. Ordering / order processing

Incorrect deliveries can only be avoided by clear and unambiguous orders. The customer is therefore required to order the parts by stating the article number. Without this identification, Almeva refuses the guarantee for error-free deliveries.

4. Delivery dates

The delivery dates confirmed by Almeva AG are binding. If a delivery date is exceeded by more than 30 days, the customer is entitled to withdraw from the contract after setting a reasonable grace period. Other claims due to delays in delivery are excluded.

5. Delivery

Almeva AG chooses the most favourable delivery method whenever possible. A surcharge of Fr. 25.-- will be made for express deliveries. Packaging will not be taken back.

If the customer wishes to take out transport insurance at his own expense, he must instruct Almeva AG to do so in writing.

6. Terms of Payment

If invoices are paid within 10 days, a discount of 2% of the invoice amount excluding VAT can be deducted. Otherwise, invoices must be paid within 30 days. Unjustified discount deductions will be charged subsequently. From the due date, default interest of 8% p.o. will be charged subject to the assertion of further default damages. The delivered goods remain the property of Almeva AG until full payment of the corresponding invoice amount.

7. Warranty

Almeva AG warrants that the delivered goods are free of defects. The warranty period is 12 months from delivery. The buyer must inspect the goods immediately upon receipt and notify Almeva AG any defects immediately in writing, otherwise the goods are deemed to have been approved. In the event of defects, Almeva AG will, at its discretion, (a) replace or repair the defective goods, (b) refund the purchase price for the defective goods. The customer is not entitled to any further claims derived from defects of the goods.

8. Limitation of liability

The warranty obligations of Almeva AG are exhaustively regulated in section 7. Under no circumstances is the customer entitled to compensation for damage that has not occurred to the delivery item itself, such as, production defects, production downtimes, loss of use, lost profits, as well as other direct or indirect damage.

The warranty is excluded in the case of:

- natural wear and tear
- in the case of unsuitable or improper use or fuels
- faulty design or assembly
- in the case of excessive strain
- external influences
- lack of or improper maintenance
- in the event that the customer or a third party undertakes remedial work without the consent of Almeva AG

9. Export ban USA / Canada

The purchaser undertakes not to export the goods (separately or in combination with other products) to the USA or Canada.

10. Applicable law

The legal relationship between Almeva AG and the customer shall be governed by Swiss law. The Vienna Sales Convention (UN Sales Convention) shall not apply.

11. Place of performance and jurisdiction

The place of performance and place of jurisdiction shall be Bischofszell, Switzerland. However, Almeva AG is also entitled to sue the customer at his registered place of business.

KOMPLETTER SERVICE - FRAGEN SIE IMMER NACH EINEM QUALIFIZIERTEN INSTALLATEUR

INSTALLATION UND KUNDENDIENST

Die Zufriedenheit unserer Kunden ist uns auch nach dem Verkauf sehr wichtig.

Die Installationen von Kaminen oder Abzügen müssen von qualifiziertem und autorisiertem Fachpersonal gemäss EN 10683 Rechtsvorschrift durchgeführt werden.

Unsere kompetenten Partner mit gut und professionell ausgebildetem Personal können wir empfehlen für: die Installation und Inbetriebnahme der Pellet-Öfen, Pellet-Heizungen und Holz-Herde

Garantiearbeiten mit Ersatzteilen (innerhalb der Werksgarantie) Service-, und Reparaturarbeiten sowie 24 Stunden Pannen-Service

Verlassen Sie sich auf:

Servicepool AG
Station Ost 11
6023 Rothenburg
Telefon: 041 280 20 20
Email: info@servicepoolag.ch
www.servicepoolag.ch

ASSISTANCE COMPLÈTE - TOUJOURS S'ADRESSER À UN TECHNICIEN AGRÉÉ

INSTALLATION, SERVICE APRÈS-VENTE

La satisfaction de nos clients est très importante pour nous, même après la vente.

Les installations de cheminées ou de conduits doivent être réalisées par des professionnels qualifiés et autorisés conformément à la législation EN 10683.

Nous pouvons recommander notre partenaire compétent avec un personnel bien formé et professionnel pour : l'installation et la mise en service des poêles à pellets, des chauffages à pellets et des cuisinières à bois garantissent le travail avec des pièces de rechange (dans le cadre de la garantie d'usine) des travaux d'entretien et de réparation ainsi qu'un service de dépannage 24h/24.

Vous pouvez compter sur :

Servicepool AG
Station Est 11
6023 Rothenburg
Téléphone : 041 280 20 20
Email : info@servicepoolag.ch
www.servicepoolag.ch

ASSISTENZA COMPLETA - RICHIEDERE SEMPRE UN INSTALLATORE QUALIFICATO

INSTALLAZIONE E SERVIZIO CLIENTI

La soddisfazione dei nostri clienti è molto importante per noi, anche dopo la vendita.

Le installazioni di camini o canne fumarie devono essere eseguite da professionisti qualificati ed autorizzati secondo la normativa EN 10683. Possiamo raccomandare il nostro partner competente con personale professionalmente ben preparato per:

l'installazione e la messa in funzione di stufe a pellet, riscaldamento a pellet e cucine a legna con garanzia di lavoro e pezzi di ricambio (nell'ambito della garanzia di fabbrica), assistenza e riparazione così come il servizio di soccorso 24 ore.

Potete contare su:

Servicepool AG
Station Ost 11
6023 Rothenburg
Telefono: 041 280 20 20
Email: info@servicepoolag.ch
www.servicepoolag.ch

COMPLETE SERVICE - ALWAYS ASK FOR A QUALIFIED INSTALLER

INSTALLATION AND CUSTOMER SERVICE

The satisfaction of our customers is very important to us, even after the sale.

The installations of chimneys or flues must be carried out by qualified and authorized professionals in accordance with EN 10683 legislation. We can recommend our competent partner with well and professionally trained personnel for:

the installation and commissioning of pellet stoves, pellet heaters and wood-burning cookers, Warranty work with spare parts (within the factory warranty), service and repair work as well as 24-hour breakdown service.

You can rely on:

Servicepool AG
Station Ost 11
6023 Rothenburg
Phone: 041 280 20 20
Email: info@servicepoolag.ch
www.servicepoolag.ch

Finden Sie Ihren Verkaufsleiter
Trouvez votre directeur des ventes
Trova il tuo responsabile vendite
Find your sales manager

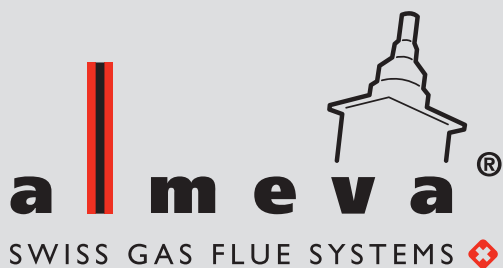
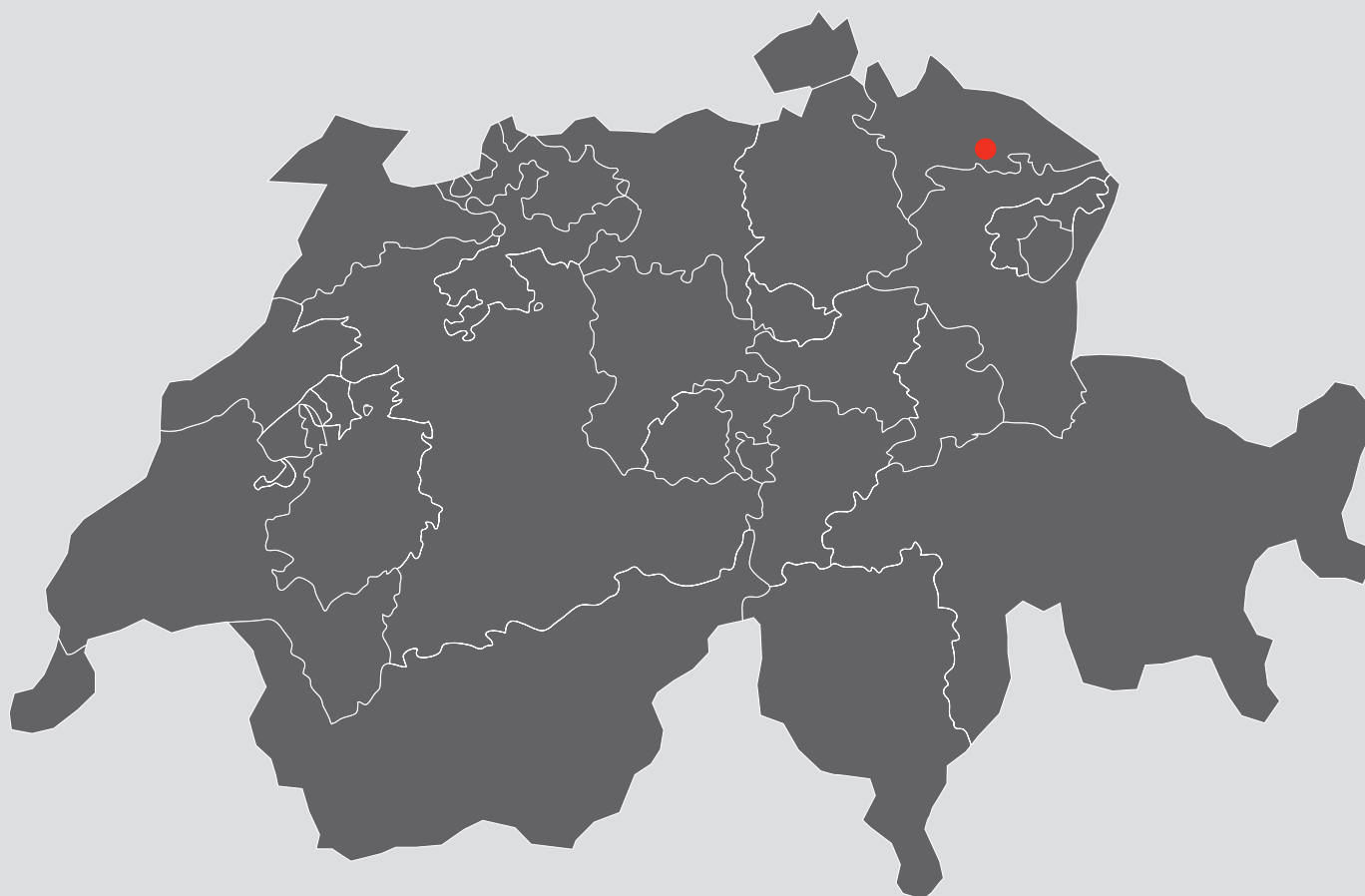

almeva AG
Industriestrasse 6
CH-9220 Bischofzell
Switzerland
Tel.: +41 71 644 90 20
E-mail: info@almeva.ch